

TOSHIBA PHOTOCOUPLER GaAlAs IRED & PHOTO-DIODE ARRAY

TLP590B

TELECOMMUNICATION
 PROGRAMMABLE CONTROLLERS
 MOS GATE DRIVER
 MOS FET GATE DRIVER

The TOSHIBA TLP590B consists of an aluminum gallium arsenide infrared emitting diode optically coupled to a series connected photo-diode array in a six lead plastic DIP package.
 TLP590B is suitable for MOS FET Gate Driver.

● UL Recognized : UL1577, File No. E67349

SHORT CURRENT

TYPE NAME	CLASSIFICATION	SHORT CURRENT		MARKING OF CLASSIFICATION
		(Min.)	I _F	
TLP590B	C20	20 μA	10mA	20
	Standard	12 μA		20, blank

(Note) Application type name for certification test, please use standard product type name, i.e. TLP590B (C20) : TLP590B

MAXIMUM RATINGS (Ta = 25°C)

CHARACTERISTIC		SYMBOL	RATING	UNIT
LED	Forward Current	I _F	50	mA
	Forward Current Derating (Ta ≥ 25°C)	ΔI _F / °C	-0.5	mA / °C
	Pulse Forward Current (100 μs pulse, 100pps)	I _{FP}	1	A
	Reverse Voltage	V _R	3	V
	Junction Temperature	T _j	125	°C
DETECTOR	Forward Current	I _{FD}	50	μA
	Reverse Voltage	V _{RD}	10	V
	Junction Temperature	T _j	125	°C
Storage Temperature Range		T _{stg}	-55~125	°C
Operating Temperature Range		T _{opr}	-40~85	°C
Lead Soldering Temperature (10sec.)		T _{sol}	260	°C
Isolation Voltage (AC, 1min., R.H. ≤ 60%) (Note 1)		BV _S	2500	V _{rms}

(Note 1) Device considered a two terminal device : Pins 1, 2 and 3 shorted together, and pins 4 and 6 shorted together.

Unit in mm

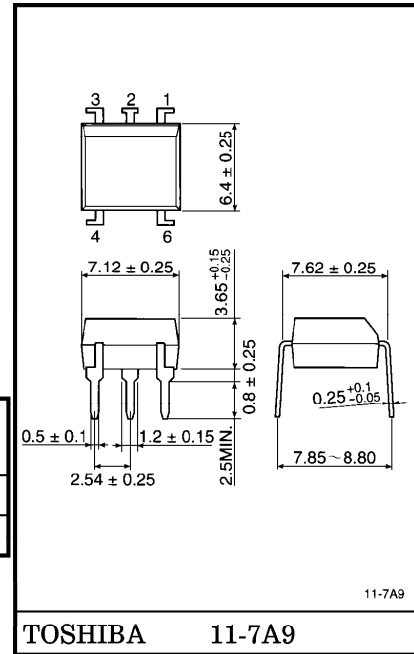

Weight : 0.39g

PIN CONFIGURATION (TOP VIEW)

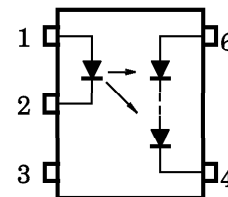

- 1. : ANODE
- 2. : CATHODE
- 3. : NC
- 4. : CATHODE
- 6. : ANODE

961001EBC2

● TOSHIBA is continually working to improve the quality and the reliability of its products. Nevertheless, semiconductor devices in general can malfunction or fail due to their inherent electrical sensitivity and vulnerability to physical stress. It is the responsibility of the buyer, when utilizing TOSHIBA products, to observe standards of safety, and to avoid situations in which a malfunction or failure of a TOSHIBA product could cause loss of human life, bodily injury or damage to property. In developing your designs, please ensure that TOSHIBA products are used within specified operating ranges as set forth in the most recent products specifications. Also, please keep in mind the precautions and conditions set forth in the TOSHIBA Semiconductor Reliability Handbook.

RECOMMENDED OPERATING CONDITIONS

CHARACTERISTIC	SYMBOL	MIN.	TYP.	MAX.	UNIT
Forward Current	I_F	—	20	25	mA
Operating Temperature	T_{opr}	-25	—	85	°C

INDIVIDUAL ELECTRICAL CHARACTERISTICS ($T_a = 25^\circ\text{C}$)

CHARACTERISTIC		SYMBOL	TEST CONDITION	MIN.	TYP.	MAX.	UNIT
LED	Forward Voltage	V_F	$I_F = 10\text{mA}$	1.2	1.4	1.7	V
	Reverse Current	I_R	$V_R = 3\text{V}$	—	—	10	μA
	Capacitance	C_T	$V = 0, f = 1\text{MHz}$	—	30	60	pF
DETECTOR	Forward Voltage	V_{FD}	$I_{FD} = 10\mu\text{A}$	—	7	—	V
	Reverse Current	I_{RD}	$V_{RD} = 10\text{V}$	—	1	—	nA
	Capacitance (Anode to Cathode)	C_{TD}	$V = 0, f = 1\text{MHz}$	—	—	—	pF

COUPLED ELECTRICAL CHARACTERISTICS ($T_a = 25^\circ\text{C}$)

CHARACTERISTIC	SYMBOL	TEST CONDITION	MIN.	TYP.	MAX.	UNIT
Open Voltage	V_{OC}	$I_F = 10\text{mA}$	7.0	8.0	—	V
Short Current	I_{SC}	$I_F = 10\text{mA}$	12	20	—	μA

ISOLATION CHARACTERISTICS ($T_a = 25^\circ\text{C}$)

CHARACTERISTIC	SYMBOL	TEST CONDITION	MIN.	TYP.	MAX.	UNIT
Capacitance Input to Output	C_S	$V_S = 0, f = 1\text{MHz}$	—	0.8	—	pF
Isolation Resistance	R_S	$V_S = 500\text{V}, \text{R.H.} \leq 60\%$	5×10^{10}	10^{14}	—	Ω
Isolation Voltage	BV_S	AC, 1 minute	2500	—	—	Vrms
		AC, 1 second in oil	—	5000	—	Vrms
		DC, 1 minute in oil	—	5000	—	Vdc

SWITCHING CHARACTERISTICS ($T_a = 25^\circ\text{C}$)

CHARACTERISTIC	SYMBOL	TEST CONDITION	MIN.	TYP.	MAX.	UNIT
Turn-on Time	t_{on}	$I_F = 20\text{mA}, R_{SH} = 510\text{k}\Omega$	—	0.2	—	ms
Turn-off Time	t_{off}	$C_L = 1000\text{pF}$ (Fig.1)	—	1	—	ms

Fig.1 SWITCHING TIME TEST CIRCUIT

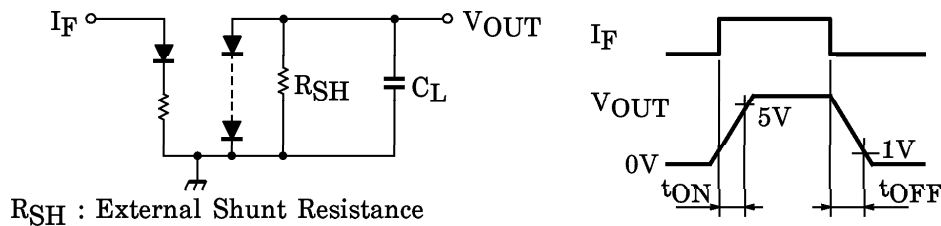

961001EBC2'

- Gallium arsenide (GaAs) is a substance used in the products described in this document. GaAs dust and fumes are toxic. Do not break, cut or pulverize the product, or use chemicals to dissolve them. When disposing of the products, follow the appropriate regulations. Do not dispose of the products with other industrial waste or with domestic garbage.
- The products described in this document are subject to foreign exchange and foreign trade control laws.
- The information contained herein is presented only as a guide for the applications of our products. No responsibility is assumed by TOSHIBA CORPORATION for any infringements of intellectual property or other rights of the third parties which may result from its use. No license is granted by implication or otherwise under any intellectual property or other rights of TOSHIBA CORPORATION or others.
- The information contained herein is subject to change without notice.

